

DRAWING MADE IN THIRD ANGLE PROJECTION

© COPYRIGHT 1976 BY AMP INCORPORATED, HARRISBURG, PA.
 ALL INTERNATIONAL RIGHTS RESERVED. AMP INCORPORATED PRODUCTS
 COVERED BY U. S. AND FOREIGN PATENTS AND/OR PATENTS PENDING.

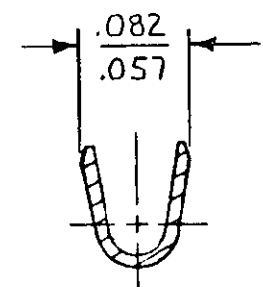

SECTION A-A
NOT TO SCALE

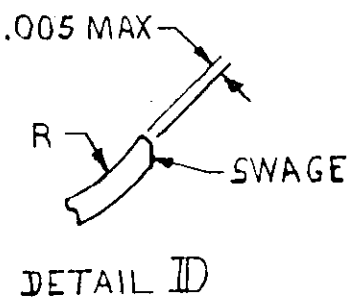
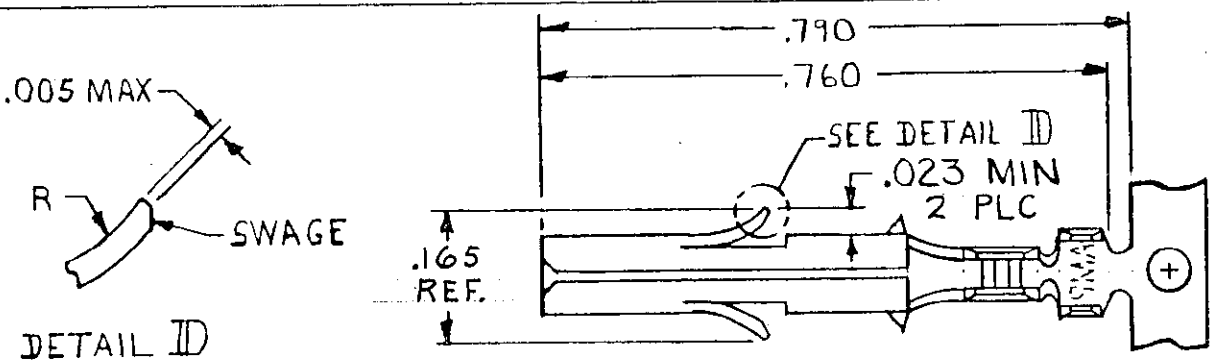
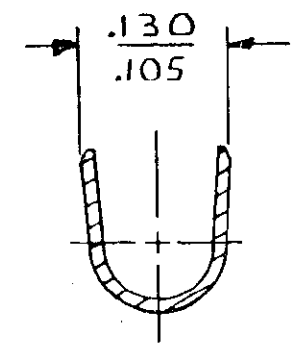
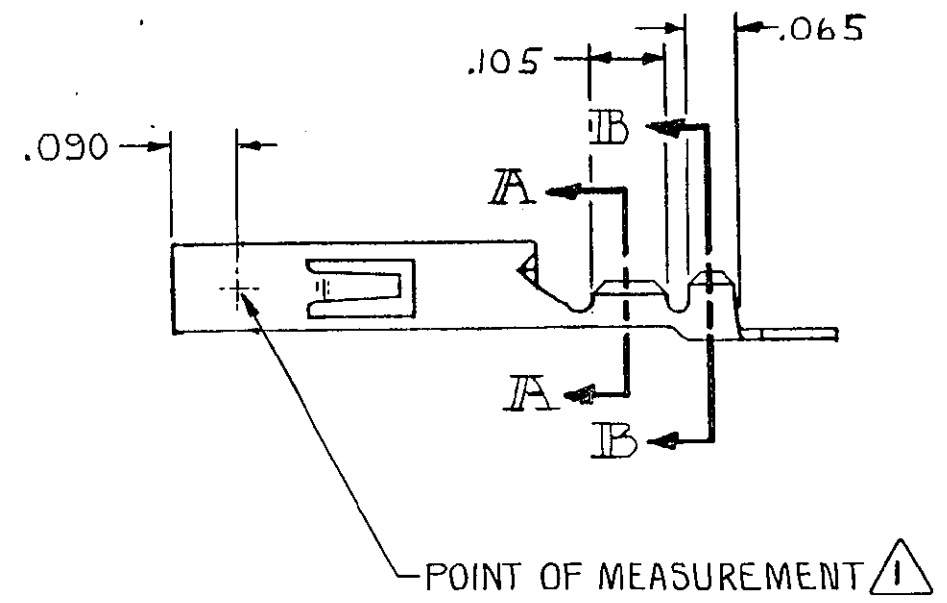

SECTION B-B
NOT TO SCALE

REVISIONS						
P	H	ZONE	LTR	DESCRIPTION	DATE	APPROVED
✓			E	REDRAWN W/O CHANGE M-6457	6-5-81	MSF/DH
✓			F	REVISED AG 57	10/21/83	SP W. K. Miller S. J. James
✓			G	ADDED -6 PER TTI CM 84-03	9-27-81	KW / RJ
✓			G1	RESTORATION	4-23-89	ST / KB
✓			H	OBSOLETE -6 PER CM-2604	11-2-89	PKC / RS
✓			J	REVISED PER CM-2812	3-26-90	PKC / RS
			K	REACT. -6 PER PR CM 91-144	12-17-91	DS / RS
			L	REV PER EC 0730-3607-91	1-6-94	RV / RS

△ .000030 MIN. GOLD OVER .000050 NICKEL.

FINISH	MATERIAL	PART NO
△	.012 PH BRZ	350925-6
PRE-TIN	.012 BRASS	350925-1

UNLESS OTHERWISE SPECIFIED DIMENSIONS ARE IN INCHES. TOLERANCES ON: DECIMALS ± .015 ANGLES ±	CONTRACT NO	AMP INCORPORATED Harrisburg, Pa.			
	DR			m. Feher 4-21-81	
	WIRE RANGE	CHK	NAME SOCKET, UNIVERSAL MATE-N-LOK		
30-26 AWG	D. S. Heide 6/9/81				
INSULATION RANGE .032-.057 DIA	APPD	APPD	SIZE	CODE IDENT NO	DRAWING NO
		R. Polakof 6-10-81	B	00779	350925
	DSGN APPD	OTHER APPD	SCALE	SHEET	
			4-1	—	